

**ELCOROCK® FILLING FRAME & J-BINS**  
**2.5m<sup>3</sup> Sand Containers**

<b>Equipment Number</b>			
<b>Customer</b>			
<b>Dispatch/Receipt</b>	Date Out    /    /	Date In    /    /	
<b>Store Location</b>			
<b>Expected Return Date</b>			

Item Number	Number of items	Item name	Checked OUT	Checked IN	Comments
1	1	Base			
2	1	Support Post			
3	1	Hopper			
4	1	Protection Plate, including 3 bolts in utility box			
5	2	J-Bin Attachments			
6	1	Utility Box			
7	1	Hose			
8	1	Clamp & Pulley System			
9	2	Circular Clamps			
10	1	Documentation (17 pages)			

This equipment has received an in-service inspection and was found to have no obvious defects.

**CHECKED OUT BY**
**CHECKED IN BY**

Name:

Name:

Signature:

Signature:

**Comments:** \_\_\_\_\_

\_\_\_\_\_

\_\_\_\_\_

### Dear Customer

On receipt of this equipment, please check all equipment has been received, ensure your site personnel read and understand the operating, maintenance, installation and safety information, and use the equipment in a safe manner.

- You are responsible for the safe operation of the equipment and the safety of your personnel.
- Standard Occupational, Health and Safety guidelines should be followed as per normal site operations. Site safety and safe work practices are your responsibility.
- At the conclusion of the use of the equipment, please clean the equipment, repack it for transportation and return to Geofabrics.
- Please advise if there are any missing parts. All equipment usage must be in accordance with Geofabrics' Hire Agreement. You will be charged for any damaged or missing components.

### ELCOROCK® FILLING FRAME & J-BIN - OPERATING AND SAFETY INSTRUCTIONS

#### **WARNING!**

- Any alterations to this hire equipment may prove dangerous to the operator and will be in breach of the Equipment Hire Agreement.
- Service must only be performed by an authorised Geofabrics service organisation or representative.
- Please contact Geofabrics (0800 60 60 20) for return of this equipment or servicing if it is found to be faulty.
- All hire related documentation, operating and safety instructions are available on our website ([www.geofabrics.co.nz](http://www.geofabrics.co.nz)).



The ELCORO<sup>CK</sup>® Filling Frame and J-Bins are intended for supporting 2.5m<sup>3</sup> ELCORO<sup>CK</sup>® containers while being filled with sand by excavators.

This document is intended to provide an outline for the safe use of the ELCORO<sup>CK</sup>® Filling Frame and J-Bins. Refer to the ELCORO<sup>CK</sup>® Installation Guidelines for 2.5m<sup>3</sup> Containers, for a comprehensive explanation of the recommended installation process.

### **Pre-operational considerations**

- Before setting up the ELCORO<sup>CK</sup>® Filling Frame and J-Bins, it is important that you read and understand the ELCORO<sup>CK</sup>® Installation Guidelines for 2.5m<sup>3</sup> Containers and the maintenance and safety precautions outlined below and in the Equipment Hire Agreement document (Use and Maintenance).
- Contact Geofabrics (0800 60 60 20) if you do not understand any of the instructions in this document.
- To operate the ELCORO<sup>CK</sup>® Filling Frame and J-Bins, operators must be in good physical and mental condition. Do not operate if on medication or under the influence of alcohol or drugs. Seek medical advice if unsure. The filling frame and bins must not be operated by a minor.
- As the filling and installation of ELCORO<sup>CK</sup>® products is considered a construction activity, the contractor using the hire equipment must prepare and implement a site safety plan that incorporates the safe work methods for high risk work involving ELCORO<sup>CK</sup>® Filling Frame and J-Bins. Including the potential need to work at height on the equipment.

### **Safety Precautions and Working Techniques**

- As the ELCORO<sup>CK</sup>® Filling Frames and J-Bins are utilised in conjunction with the operation of large mobile plant and construction equipment, safety precautions must be observed to reduce the risk of personal injury.
- Always use appropriate personal protective equipment (PPE) such as hard hats with brim attached, broad brim hats, safety eye wear with side protectors, sunglasses, sunscreen, high visibility clothing, long sleeve shirts, riggers gloves, steel toe capped boots, etc.
- Personnel involved in sand filling activities must wear hard hats and any other relevant PPE.
- The ELCORO<sup>CK</sup>® Filling Frame and J-Bins must be assembled as per the ELCORO<sup>CK</sup>® Installation Guidelines for 2.5m<sup>3</sup> Containers.
- Do not use the ELCORO<sup>CK</sup>® Filling Frame and J-Bins for any application other than its intended purpose.
- Do not abuse the ELCORO<sup>CK</sup>® Filling Frame and J-Bins in any way which may result in personal injury and/or damage to the equipment.
- Check the condition of the ELCORO<sup>CK</sup>® Filling Frame and J-Bins before each use for any damage. If the behaviour of the filling frame and bins changes, check it immediately and return it to Geofabrics for service if necessary.
- Never modify the provided equipment in any way.

## Site Conditions

- The contractor should take into consideration site specific planning of the layout and logistics regarding filling, storage and placement will reduce OSH risks, enhance productivity and minimize excessive handling or travelling.
- Consideration should also be given to the filling area founding conditions as many installations of ELCOROCK® containers are conducted on comparatively soft or loose sub-grades such as beaches and riverbanks.
- The filling area must be clear of debris and level with stable founding conditions.

**Warning** If the works area is not level and base conditions stable, the filling frame/bins could potentially fall over possibly causing injury to personnel/public and/or damage to plant/ equipment.

If ground stability changes due to repeated/prolonged use or changing environmental conditions, cease operations until appropriate remediation works are undertaken to provide on-going stability to the filling frame.

- The ELCOROCK® container filling/placement operation should not be conducted in conditions which will endanger the operator, site personnel or the public.

## Filling Process

- Filling should be conducted as per the ELCOROCK® Installation Guidelines for 2.5m<sup>3</sup> Containers.

**Warning** If there is a need to work from height on the ELCOROCK® Filling Frame and J-Bins, this needs to be taken into account by the contractor's site safety plan.

Refer to the Health and Safety provisions in Employment Act 1992 regarding the need to take all practicable steps to ensure safety of workers. Further information on how to prevent falls from height can be obtained from the Department of Labour at [www.dol.govt.nz](http://www.dol.govt.nz) and Site Safe New Zealand at [www.sitesafe.org.nz](http://www.sitesafe.org.nz)

- Ensure that there is only one worker at any one time under the hopper manning the hose valves when sand is being deposited into the hopper. The worker must be wearing a hard hat and be positioned under the protection plate (extends approximately 280mm from side of hopper) whenever sand is being delivered to the hopper.

## Maintenance

- All mechanical components should be checked daily, including bolted components, valves and load bearing items.
- To keep the ELCOROCK® Filling Frame and J-Bins performing well in the field, please ensure it is kept clean.
- It is the responsibility of the customer to return the ELCOROCK® Filling Frame and J-Bins in good and clean condition. All damages shall be charged to the customer.
- All routine maintenance and repairs shall be carried out by Geofabrics or its authorised repairer, to ensure the equipment remains reliable.

**ELCOROCK® FILLING FRAME & J-BIN COMPONENTS**

The ELCOROCK® Filling Frame and J-Bins consists of a free standing hopper complete with two J-Bin cradles (Fig 3,4,5) and is accompanied by 2 J-Bin attachments (Fig 7), a number of smaller components are also included to set up the filling frame and bins.

To ensure no parts are lost, all components should be stored and transported as a set, in such a way as not to cause damage to the equipment (Fig 2).



Figure 2



Figure 3



Figure 4



Figure 5



Figure 6



Figure 7



Figure 8



Figure 9



Figure 10



Figure 11



Figure 12

### **ELCOROCK® Filling Frame Base (Fig 5)**

- Check the base is not bent or has major dents.

### **Hopper Column Support Post (Fig 3)**

- Check the support post is not bent or has major dents.

### **Hopper (Fig 4, 6)**

- Check the hopper is not bent or has major dents.
- Check all 8 hoses are securely connected and not damaged or blocked.

### **Protection Plate (Fig 4, 6, 9)**

- Check the plate is not bent or has major dents.
- Check the 3 protection plate bolts are in the utility box.
- Check the 3 protection plate bolts are correct and not damaged.

### **J-Bins (Fig 7)**

- Check the J-Bins are not bent or have major dents.
- Check the quick hitch area is not significantly damaged.

### **Utility Box (Fig 8)**

- Check the utility box has no major dents.
- Check the contents of the utility box:
  - 3 protection plate bolts
  - Hose
  - Clamp and pulley system
  - Circular clamps

### **3 protection plate bolts (Fig 9)**

- Check the 3 protection plate bolts are correct and not damaged.

### **Hose (Fig 10)**

- Check the hose is not damaged.

### **Clamp & Pulley System (Fig 11)**

- Check the clamp is not bent.
- Check the rope is not frayed or damaged.

### **Circular Clamps (Fig 12)**

- Check the clamps not bent or damaged.
- Check the fastening mechanism functions correctly.
- Check the clamps open and close around the filling ports effectively.

# ELCOROCK<sup>®</sup>

Installation Guidelines

2.5m<sup>3</sup> Sand Containers

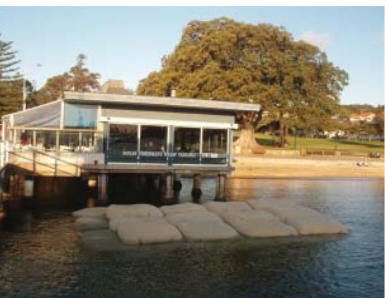

Quality - Support - Expertise





# ELCOROCK® Installation Guidelines

Please read the important notice at the end of this brochure

## Contents

1.0	Introduction.....	3
2.0	Packaging, Transport and Unloading on Site.....	3
3.0	On Site Storage.....	4
4.0	Installation Requirements.....	4
5.0	Equipment compatability .....	4
6.0	Site and Subgrade Preparation.....	6
7.0	Site and Weather Conditions for Installation .....	7
8.0	Filling and Placement Apparatus.....	7
9.0	Filling .....	8
10.0	Closure.....	9
11.0	Placement and Handling .....	10
12.0	Production Targets .....	11
13.0	Maintenance.....	12



These guidelines are general in nature. Site or project specific conditions may require them to be altered or amended to ensure effective installation. Please follow the guidance of the consulting or site engineer.

## 1.0 INTRODUCTION

ELCOROCK® engineered sand containers offer excellent performance in durability, robustness and usability. ELCOROCK® sand containers offer the designer, contractor and end user a range of benefits over traditional rock or hessian bag type structures, including more consistent physical properties, a well structured installation process and an amenable, user-friendly end product.

ELCOROCK® 2.5m<sup>3</sup> sand containers are designed with the harsh conditions of the open shoreline in mind. Constructed from heavy duty staple-fibre polyester and polyester/polypropylene blends, the ELCOROCK® product is capable of withstanding some of the harshest conditions on the planet, ranging from prolonged exposure to extreme ultra-violet radiation to withstanding the devastating effects of a category five cyclone.

The installation of the ELCOROCK® 2.5m<sup>3</sup> sand containers is a structured process that has been developed to ensure it is capable of delivering rapid construction times. This document provides a detailed outline of the procedures that should be followed in order to correctly store, fill and install ELCOROCK® 2.5m<sup>3</sup> sand containers.

Standard Occupational, Health and Safety guidelines should be followed as per normal site operations. Site safety and safe work practices are the responsibility of the consultant and/or contractor.

## 2.0 PACKAGING, TRANSPORT AND UNLOADING ON SITE

ELCOROCK® 2.5m<sup>3</sup> sand containers are supplied wrapped in waterproof, UV resistant, opaque plastic stretch-wrap on a pallet. For quantities of sand containers per pallet refer to Table 1. Transportation of sand containers is usually by flat-bed truck or similar and unloading should be conducted on the pallet as a whole, leaving the protective wrap in place until such time as the sand containers are required for filling. Unloading from the pallet should take place as required and remaining sand containers should be covered with the plastic wrap to prevent water ingress or exposure. Failure to do this may lead to saturation of the bags, making them heavy and difficult to handle.

**Table 1: Packaging**

Geotextile	Number of containers per pallet
Standard	30
Vandal deterrent one side	25
Vandal deterrent	20

## 3.0 ON SITE STORAGE

All deliveries of ELCOROCK® sand containers should remain in as-delivered protective wrapping until filling and placement commences. Ideally, sand containers should be stored in a location that offers protection from the elements, particularly for longer storage periods.

## 4.0 INSTALLATION REQUIREMENTS

The following are the minimum requirements to ensure a good filling and placement rate of 2.5m<sup>3</sup> ELCOROCK® sand containers;

- Filling apparatus, including J-Bins (supplied). Ensure compatibility of excavator quick hitches (refer to Table 2 and Figure 1),
- 50mm lay flat high pressure hose with quick lock fittings (supplied),
- Container lifting device, consisting of clamp, pulleys and rope,
- Silicon adhesive (supplied),
- Cable ties (supplied),
- 2" high pressure water pump/supply,
- 13 tonne or similar excavator for filling sand containers,
- 35 tonne or similar suitable (refer to Figure 2) excavator for placement of sand containers,
- 3 labourers plus excavator operators,
- Personal protection: hats, steel cap boots, sunglasses, sun screen, long sleeve shirts.

Before installing ELCOROCK® sand containers this guideline should be read thoroughly by all installation personnel. The installation team should be aware of their individual roles in ensuring a quality installation. Any questions raised by the installation team which cannot be answered by this document should be referred to the supplier.

## 5.0 EQUIPMENT COMPATIBILITY

The J-Bins have been designed to accept a wide range of different excavators by means of an interchangeable quick hitch attachment. If the equipment available does not match the standard quick hitches available (refer to Table 2), project specific hitches can be manufactured to suit. The contractor should allow at least one month for the manufacture of new quick hitch attachments.

For removal of the J-Bins from the filling apparatus, a 35 tonne excavator is recommended. This size machine allows removal on J-Bins from one side of the apparatus only, which simplifies the removal and placement operation and ensures enough clearance around the apparatus (refer to Figure 2).

**Figure 2: Apparatus Clearance Requirements**

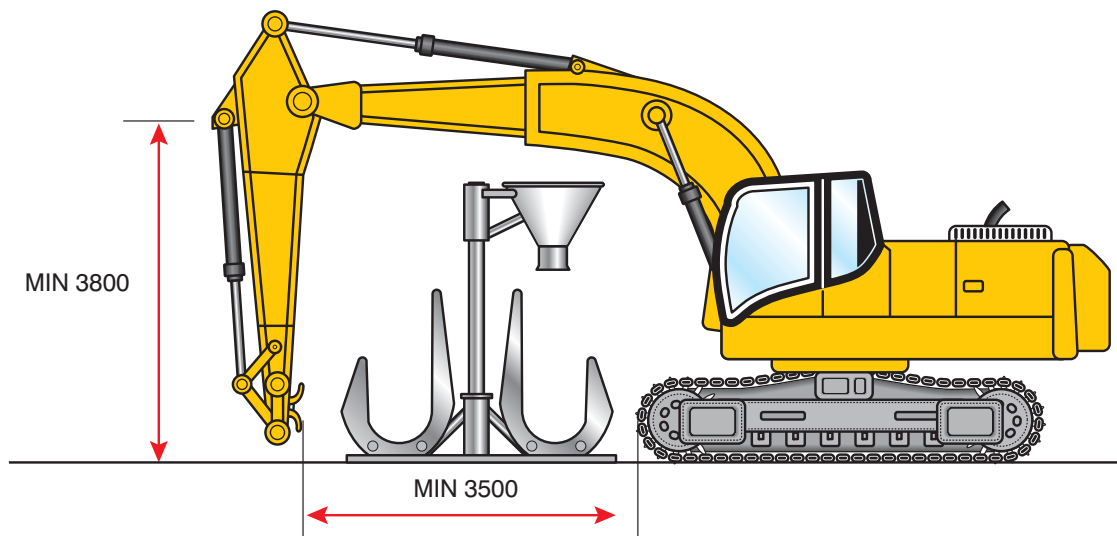

## 6.0 SITE AND SUBGRADE PREPARATION

Depending on the size of the project and the number of units to fill, planning of the site layout and logistics regarding filling and placement will enhance productivity and minimise the need for excessive handling or travelling. Access to J-Bins can be from one side for sites with limited space or from two sides where a larger working area is available or where excavators smaller than 35 tonnes are used (refer to Figure 3 and Figure 4).

**Figure 3: Minimum Apparatus One Side Access Area**

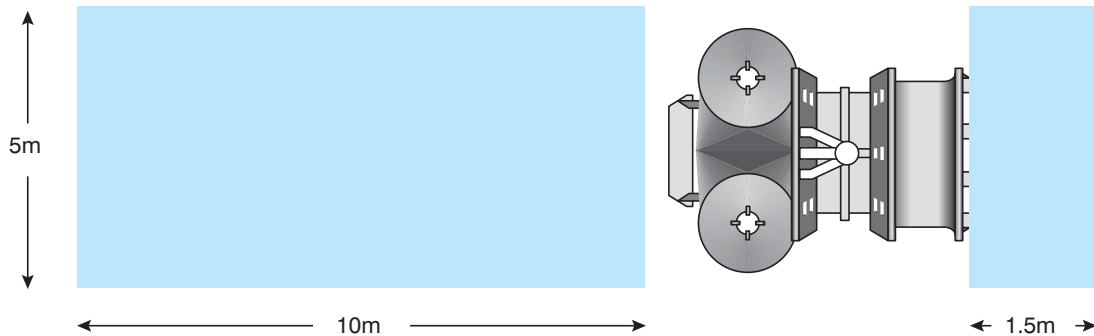

**Figure 4: Minimum Apparatus Two Side Access Area**

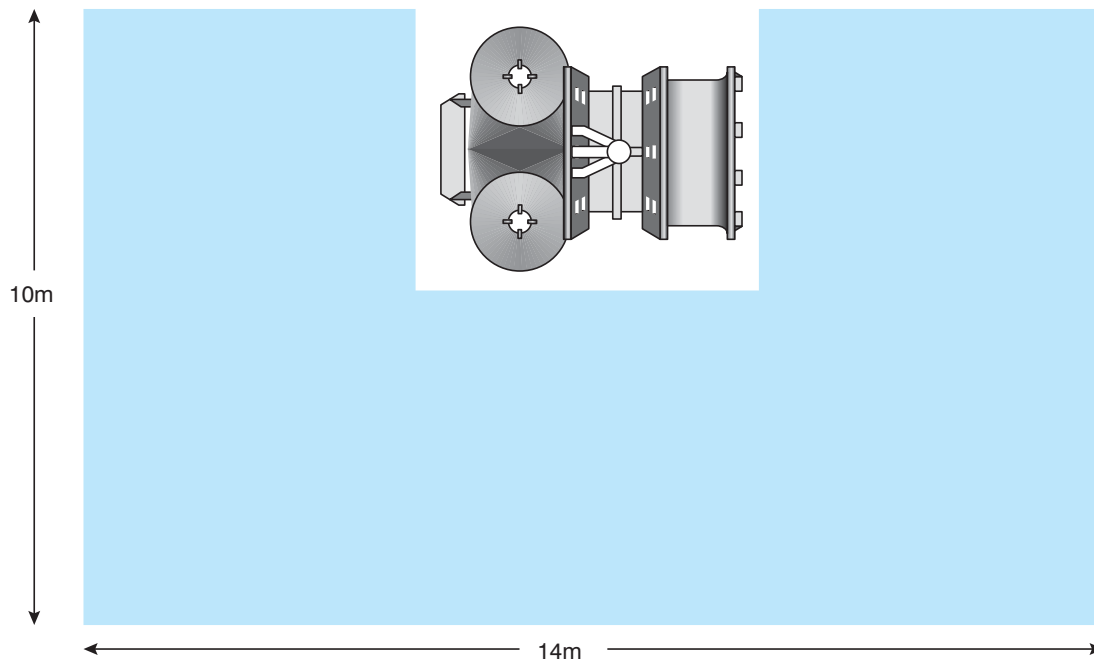

The site must be prepared such that there is no debris and the filling area is level and firm. Failure to ensure a level and firm construction area may lead to damage or instability of the filling apparatus. If the apparatus is not level it will be more difficult to connect to the quick hitch.

## 7.0 WEATHER CONDITIONS FOR INSTALLATION

ELCOROCK® installations can be sensitive to climatic conditions including tides, waves, rain and wind. Tidal variations may influence the availability of fill material, ability to place the containers and the area available to work and store raw materials and equipment. For safety reasons, strong or severe wave action can have an effect on the ability to work within an exposed coastal region.

Rain and wind can present hazardous situations in and around the work site, particularly where electricity is present. All of the above factors must be taken into account when planning an installation.

## 8.0 FILLING AND PLACEMENT APPARATUS

The filling apparatus (refer to Figure 5) is delivered on site dismantled. It consists of a large rectangular base with a centre upright (mast); a hopper system (which is supported by the mast) and two filling/placement J-Bins on either side of the base.

The hopper system is designed to pivot about the mast so that it is able to service either of these J-Bins when they are in position. The filling apparatus includes water filling jets which are attached to the hopper and allow for hydraulic compaction of the fill material.

To assemble the filling and placement apparatus the following steps must be followed:

1. The rectangular base must be placed in position on a level, firm foundation with drainage access (refer to Figure 6).
2. The mast is then inserted into the base, ensuring it is clean and free from debris.
3. The J-Bins are then placed on either side of the base, in the appropriate slots.
4. The hopper is then placed onto the top of the mast, ensuring it is clean and free from debris (refer to Figure 7).
5. The water supply is then connected to the splitter boxes.
6. Attach the container lifting device.



Figure 5. Filling and placement apparatus



Figure 6. Base placement



Figure 7. Hopper placement

## 9.0 FILLING

Filling of sand containers is carried out using an excavator. The bucket of the excavator should be large enough to allow rapid filling of the sand containers but limited in width so as not to spill over the edge of the hopper system.

1. Ensure a sufficient stockpile of sand for a continuous operation and filling.
2. Remove one **ELCOROCK**<sup>®</sup> sand container from the pallet and place in a filling/placement cradle.
3. Using the central pulley system, lift the **ELCOROCK**<sup>®</sup> sand container up and pull the container until the top of the container touches the bottom of the hopper.
4. Pull the filling trunks of the sand container completely over the hopper chute, ensure 3 points of contact are maintained at all times (refer to Figure 9).
5. Attach the clamp at the top of the hopper chute. The clamp must fit tightly against the chute. The container should now hang freely with the base 20 – 50mm above the base of the J-Bin.
6. Turn on the water jets. This will assist in washing the sand into the container and improve compaction of the fill material.
7. Begin to fill the sand container, slowly at first, ensuring the sand is getting into the bottom corners and no folds or creases exist or form in the sand container (refer to Figure 10).
8. Complete filling until the sand level is within 200mm of the top of the container, ensuring fill material is spread evenly, particularly into the top corners.

**Note:** Coarse sand will require higher water pressure to wash the sand into the centre of the container.

9. When filled correctly, the sand containers will achieve the minimum dimensions (refer to Figure 11).



Figure 9. Hopper chute



Figure 10. Sand fill process

Figure 11: Minimum 2.5m<sup>3</sup> Container Dimensions



Dimensions	
Depth (mm)	600
Width (mm)	1600
Length (mm)	2400

## 10.0 CLOSURE

The closure of the 2.5m<sup>3</sup> sand containers consists of a double seal system (refer to Figure 12) which reduces the risk of loss of fill material.

1. Carefully release the clamps holding the trunks.
2. Rotate the hopper system 180° to allow filling of the next container.
3. Roll the trunks down and secure through the pre-manufactured holes using the supplied cable ties. Cover the holes with silicon.
4. Push the trunks down into the sand container.
5. Lace closed the opening using the supplied cord, ensuring a double reef knot is used to tie off the cord and cover all knots with a generous amount of silicon.

Figure 12: Closure Sequence

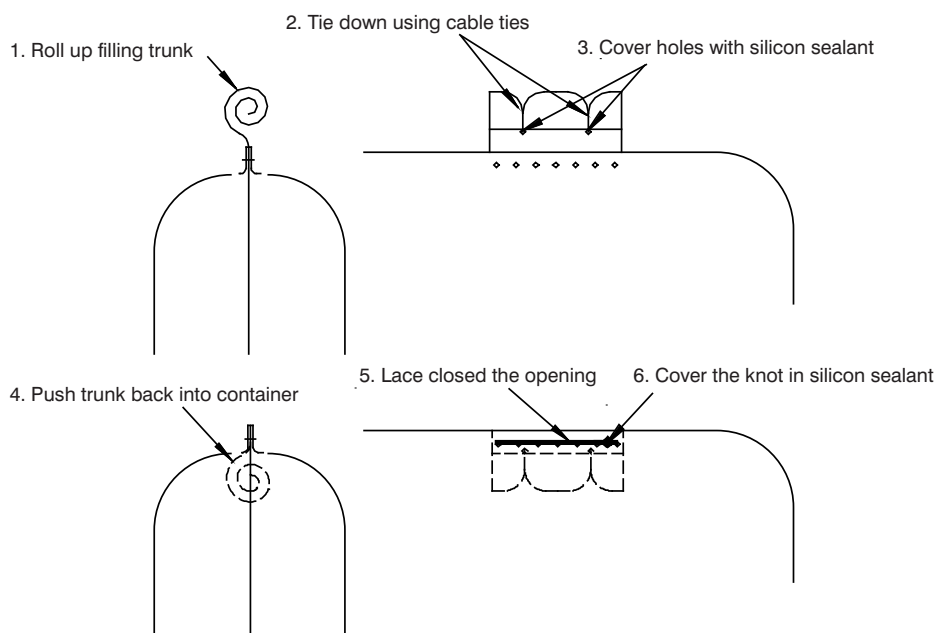

## 11.0 HANDLING AND PLACEMENT

The filling apparatus which has been specifically developed for the 2.5m<sup>3</sup> **ELCOROCK**<sup>®</sup> sand containers has also been designed for use as a placement device. A quick-hitch attachment on the container allows a 35 tonne excavator to rapidly lift sand containers from either side of the filling apparatus, ensuring a good production rate. Modified rock grabs are not suitable for use as they place the sand container under high levels of stress, which can stretch the fabric out of shape or even cause a failure of the seam.

The **ELCOROCK**<sup>®</sup> sand containers can be placed directly after the filling and closure procedure is completed. The placement of the sand container should be completed in such a way that the site closed seam is buried/hidden from exposure to prevent untying of the closure through movement or vandalism.

After placement of the **ELCOROCK**<sup>®</sup> sand container, the underside of the J-Bin can be utilised to press down on the top surface of the sand container to achieve a straight and level finish as follows:

1. Connect the excavator to the J-Bin quick hitch.
2. Lift the J-Bin off the base plate and ensure all personnel are well clear of the working area of the excavator.

**Note:** the contractor must ensure the excavator used is rated to lift the J-Bin and the saturated sand container (approximately 6 tonnes when wet).

3. Walk the excavator into position and place the sand container. A slight backwards and forwards shaking movement of the J-Bin may be required to assist in allowing the sand container to slide forward out of the J-Bin.
4. If the design requires trafficking of the sand containers during placement, a minimum sand cover depth of 500mm is required over the sand containers.

If conditions do not allow immediate placement of the **ELCOROCK**<sup>®</sup> sand containers, they should be stored on a soft, sand surface and not stacked. This is to ensure the J-Bin placement apparatus can easily dig under the sand container and lift it as shown below. Failure to do this may lead to lost production or damage to filled sand containers.

1. Slide the J-Bin under the sand container (refer to Figure 13).
2. Some sideways shaking of the J-Bin will be required to dislodge sand that has become trapped under the sand container during the lifting operation.
3. Walk the excavator into position and place the sand container. A slight backwards and forwards shaking movement of the J-Bin may be required to assist in allowing the sand container to slide forward out of the J-Bin (refer to Figure 14).



Figure 13. Sand container handling



Figure 14. Sand container placement

## 12.0 PRODUCTION TARGETS

As with any repetitive process, the key to productivity is to ensure good organisation. An organised site, well laid out with the above available assets, will comfortably fill 3 to 4 **ELCOROCK**<sup>®</sup> 2.5m<sup>3</sup> sand containers per hour. The contractor should allow for a 6-hour production period per 8-hour working day and allow for time to replenish the sand stockpile, refuel and general repairs and maintenance to equipment.

Geofabrics can supply a detailed production cost analysis spread sheet which allows site specific costs to be included for budget or costing purposes.

## 13.0 MAINTENANCE

It is the responsibility of the owner to adequately maintain the structure once complete. This will require regular inspections to identify and repair any damage that may have occurred to the structure. It is important to note that where sand containers are located in submerged or intertidal zones and they are ruptured, the sand retained within the sand container can be removed rapidly due to wave and current movements and it is imperative that repairs be carried out as soon as any damage is identified.

If the **ELCOROCK**<sup>®</sup> sand container is allowed to lose fill material to a point where the geotextile can flap, the geotextile will tear along the fatigue lines created by the flapping action and catastrophic failure of the container is likely to occur.

The following general guidelines are recommended: walk over the structure once a month; identify sand containers with damage or showing signs of deterioration; ensure all sand containers are inspected, patch or repair damaged containers immediately as per details provided in section 14.



## 14.0 REPAIRS

While the geotextile used to manufacture ELCOROCK® sand containers is extremely tough and durable, the material can be damaged by boat impact, vandalism or other factors. An effective method has been developed to patch the sand containers both above and below the waterline.

### 1. Patch preparation

- a. The patch should extend at least 300mm beyond the edge of the hole,
- b. Ensure all corners of patch are rounded 100mm radius minimum,
- c. 5mm holes should be burnt (using a hot soldering iron) at 100mm centres along the edge of the patch and 50mm in from the edge.

### 2. Surface preparation

- a. Scrub the area with a coarse brush to remove all algae growth,
- b. Shake the geotextile to dislodge the sand trapped in the outer layer of the geotextile, it will not be possible to remove all sand but the more porous the surface the better the bond between the patch and the sand container.

### 3. Patch placement

- a. Place the patch over the hole and punch a hole in the sand container using a sharpened screw driver,
- b. Screw first screw into place, continue process around the patch,
- c. Ensure a thick layer of Silastic 732 adhesive/sealant is applied to the surface of the sand container to ensure a good bond between patch and sand container
- d. After all screws are in place, press down firmly on patch to ensure the adhesive is forced into the geotextile and squeezes evenly out along the edge of the patch,
- e. Where adhesive does not extrude out from under the edge of the patch extra adhesive must be applied to the area by pushing the nozzle under the patch.

Contact Geofabrics New Zealand Ltd for advice on any unusual repairs or maintenance requirements.

Geofabrics New Zealand Ltd  
14 Goodman Place  
PO Box 12536  
Penrose  
Auckland 1642  
NEW ZEALAND  
T: (64) 9 634 6495  
F: (64) 9 634 6492  
sales@geofabrics.co.nz

Toll Free: 0800 60 60 20

Auckland  
Christchurch  
Napier  
Hamilton  
Papua New Guinea  
Fiji  
Cook Islands

Offices & Distributors:

Quality Management System  
Certificate of Registration  
ISO 9001:2008



**GEOFABRICS.CO.NZ**

#### IMPORTANT NOTICE - DISCLAIMER

The information contained in this brochure is general in nature. In particular the content of this brochure does not take account of specific conditions that may be present at your site. Site conditions may alter the performance and longevity of the product and in extreme cases may make the product wholly unsuitable. Actual dimensions and performance may vary. If your project requires accuracy to a certain specified tolerance level you must advise us before ordering the product from us. We can then advise whether the product will meet the required tolerances. Where provided, installation instructions cover installation of product in site conditions that are conducive to its use and optimum performance. If you have any doubts as to the installation instructions or their application to your site, please contact us for clarification before commencing installation. This brochure should not be used for construction purposes and in all cases we recommend that advice be obtained from a suitably qualified consulting engineer or industry specialist before proceeding with installation. © Copyright held by Geofabrics New Zealand Ltd. All rights are reserved and no part of this publication may be copied without prior permission.

M155-11/02/15

